

Model: **ALRFSM**

Description: Mains Optical Smoke Alarm With Battery Back up - Radio frequency inter-connected

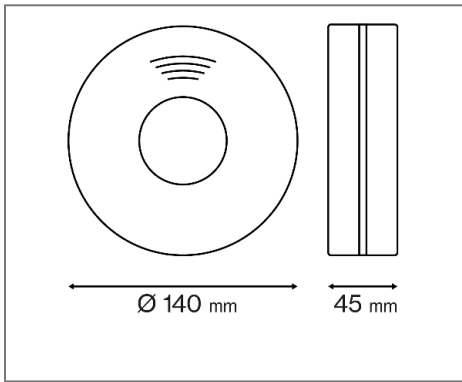

## Product Features

- Comes With A Ceiling Mounting Bracket For Convenient Mounting
- ISO 8201 Sound Pattern >85db
- Link Up to 40X Alarms
- Pairs seamlessly with wireless interconnected smoke detectors
- Test/Hush Button
- Silence function: Approx.8 mins

## Technical Information

Ambient Humidity	< 93%
Applications	Domestic Use, Offices, Bedrooms, Hotels etc
Approvals/Certifications	CE, UKCA
Battery Back Up	6LR61
Body Material	Non-flammable ABS plastic
Class	I
Input Voltage (Hz)	220-240
Operating Temperature	0-40°C
Power Source	9V
Product Colour/Finish	White
Warranty Period (Years)	5
Dimensions (mm)	140 X 45
Barcode	5027825978883

