

SHARK 525W

Classic Series

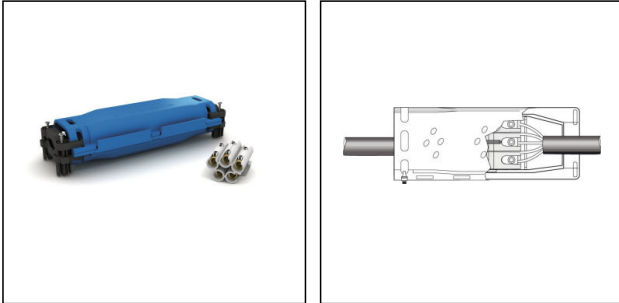

Products may differ in size, colour and appearance to those shown. If you require further information or customisation, please contact us directly.

| | |
|----------------------------|--------------------------------|
| Material | Polyamide |
| Filling | Silicone |
| Temp. range min | -20 °C |
| Temp. range max | 90 °C |
| Glow wire test | self-extinguishing |
| Voltage | 0,6 kV - 1 kV |
| Terminals/poles | 3 - 5 x 6 - 16 mm ² |
| Quantity of cable | 3 - 5 |
| Type | SHARK 525W |
| UK-Number | SH525W |
| WISKA-Order no. | 10108946 |
| Packing unit | 1 |
| ETIM-Classification | EC001169 |

Remarks:

Ampere: 135
 Cable Size: (3 core) 2.5 - 16 mm (4 core) 2.5 - 16 mm (5 core) 2.5 - 10 mm
 LxBxH: 69x180x40 mm

Description:

SHARK Pre-filled gel insulated straight joint. Includes retention clamp, earth braid and constant force roll springs. Perfect for steel wired armour cable.

Additional Info:

Ready to use, re-enterable, no mixing or pouring, immediate operation, excellent electrical insulation, good mechanical strength, no expiry date.

Your Contact:

WISKA UK Ltd.

Unit 7, Hurling Way · St. Columb Major Business Park · TR9 6SX, St. Columb Major, Cornwall · Great Britain

☎ +44-12-08816062 · 📠 +44-12-08816708



info@wiska.co.uk · www.wiska.co.uk

04.04.2023

Your Contact:

WISKA UK Ltd.

Unit 7, Hurling Way · St. Columb Major Business Park · TR9 6SX, St. Columb Major, Cornwall · Great Britain

 +44-12-08816062 ·  +44-12-08816708

info@wiska.co.uk · www.wiska.co.uk

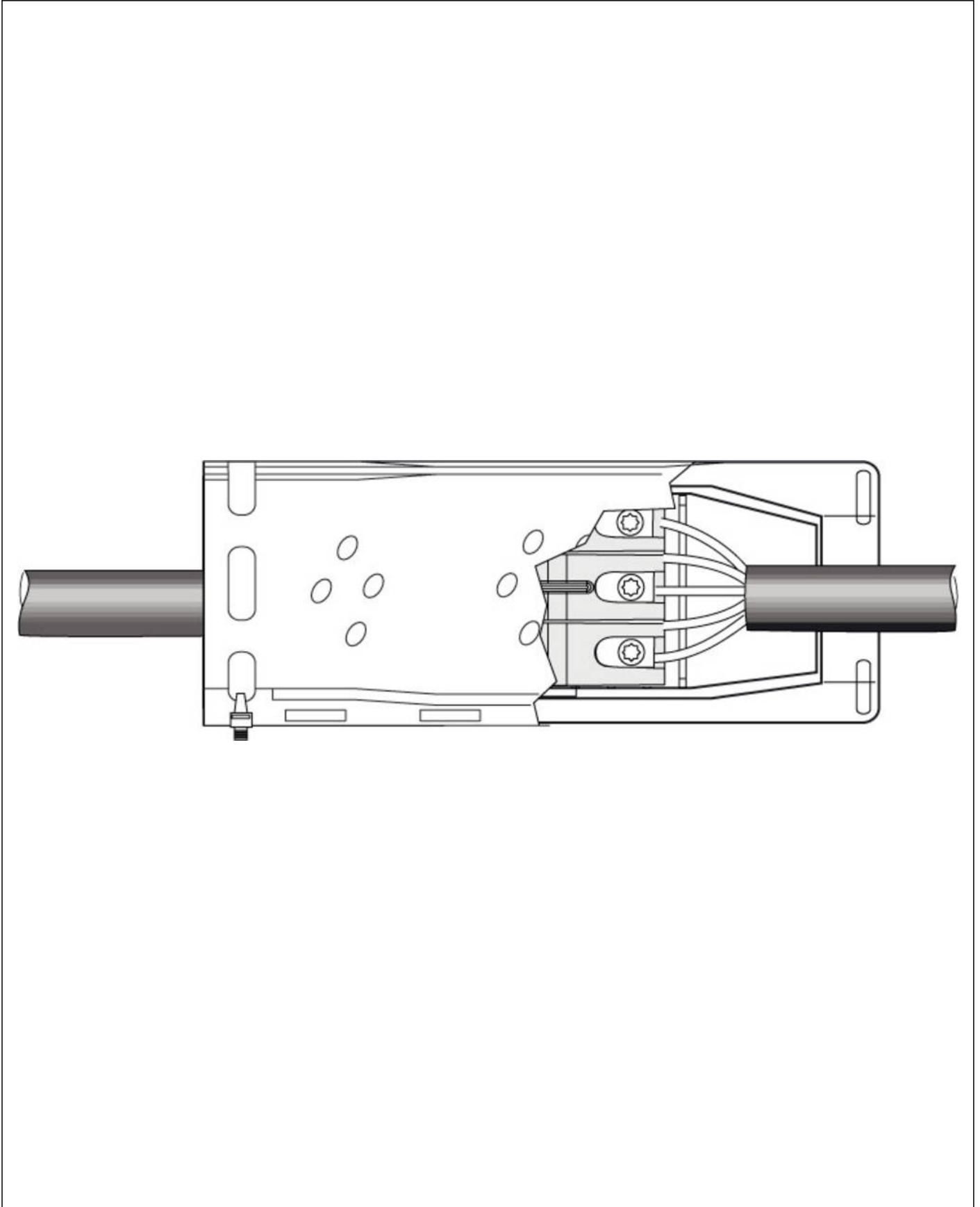

Your Contact:

WISKA UK Ltd.

Unit 7, Hurling Way · St. Columb Major Business Park · TR9 6SX, St. Columb Major, Cornwall · Great Britain

☎ +44-12-08816062 · 📠 +44-12-08816708

info@wiska.co.uk · www.wiska.co.uk